

Grease separators for free-standing installation

EasyClean Auto Mix (D+SP)

NS 2 - 10

Illustration	Article description	NS	Weight	Article #
 <p>Certification: Z-54.1-474</p> <p>Delivery: System completely assembled.</p> <p>Accessories: Sampling chamber, lifting stations, remote control, <i>TeleControl</i></p>	<p>Grease separator EasyClean Auto Mix (D+SP) NS ...</p> <p><input type="checkbox"/> according to Euro Norm EN 1825, manufactured from virgin, non-recycled polyethylene, pumping capacity 3.0 kW</p> <p>5 m cable length</p> <p>For free standing installation in frost protected areas, with integrated sludge trap, sloped interior base improves cleaning and reduces disposal time, inlet flow calming system and outlet flow regulation device, inlet and outlet interchangeable, slanted twin access covers with quick release odour tight snap closures, inspection window with interior cleaning arm, <i>D+SP</i> version with simultaneous mixing and cleaning of separator interior - requires disposal truck with vacuum system for separator disposal, disposal is completely odour free, maintenance free macerating motor (stainless steel blades) includes closure valve for easy motor removal, motor floor mount included with installation hardware and anti-vibration matt, top mounted water jet(s) for grease layer breakup and water spray nozzles for interior wall cleaning during disposal, 1 inch interior thread refill inlet with air gap, with LCD display control unit settable in English, German or French language and mains power safety on/off switch, with BMS connections, twin 1 inch solenoid valves for connection of cold and hot water pipes to separator, with remote control offering full separator disposal control from remote location (from disposal truck location), 75 mm OD PN 10 pressure disposal pipe, with integrated fork lift grips at base of separator, low weight - compact design, 100 % corrosion free polyethylene body construction (20 year warranty).</p>	NS 2	150 kg	without <i>SonicControl</i>
		NS 3	155 kg	93 002.01/DSP
		NS 4	168 kg	93 003.01/DSP
		NS 7	216 kg	93 004.01/DSP
		NS 10	262 kg	93 007.01/DSP
				93 010.01/DSP
		NS 2	150 kg	with <i>SonicControl</i>
		NS 3	155 kg	93 002.02/DSP
		NS 4	168 kg	93 003.02/DSP
		NS 7	216 kg	93 004.02/DSP
NS 10	262 kg	93 007.02/DSP		
		93 010.02/DSP		

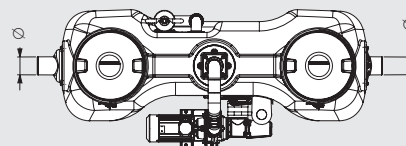
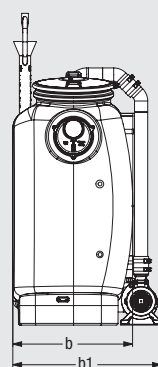
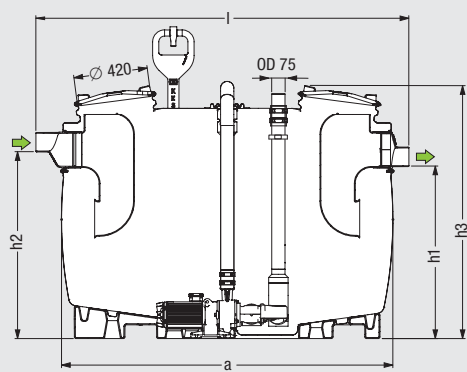

Ø = Outer diameter
b1 = Set-up dimensions

Technical note see page 283

Nominal size	Ø	Installation dimensions				b1	h1	h2	h3	Sludge	Grease	Total (including water)
		a	l	x	b							
NS 2	110	1500	1735		680	860	985	1055	1435	200 l	100 l	600 l
NS 3	110	1500	1735		680	860	985	1055	1435	300 l	120 l	600 l
NS 4	110	1880	2115		680	860	985	1055	1435	400 l	160 l	800 l
NS 7	160	1910	2145		940	1130	1185	1255	1655	700 l	280 l	1350 l
NS 10	160	2590	2820		940	1130	1185	1255	1655	1000 l	400 l	1900 l

Grease separators for free-standing installation

Installation example *EasyClean Auto Mix (D+SP)*

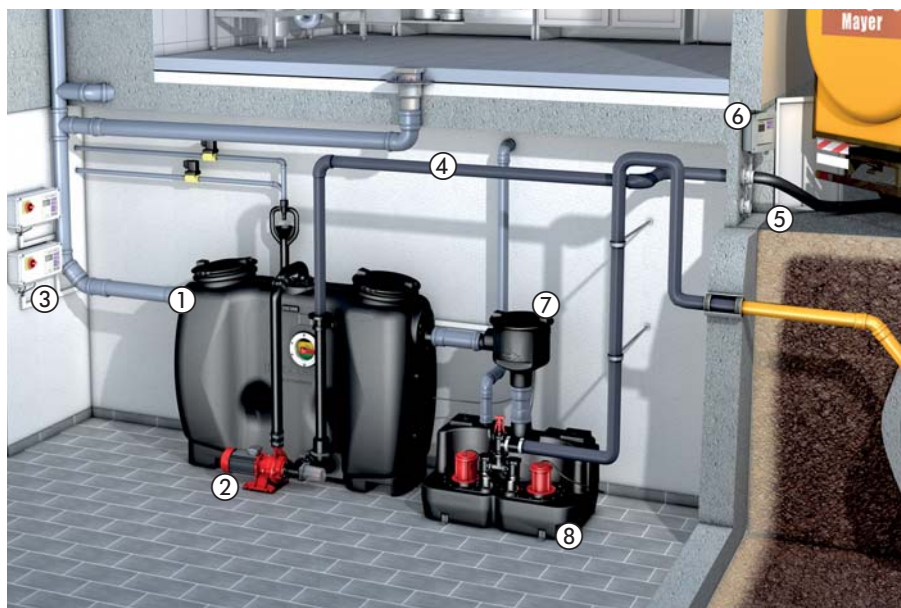

- | | |
|-----------------------|------------------------------------|
| ① Grease separator | ⑤ Connection for disposal truck |
| ② Shredder-Mix-System | ⑥ Remote control system (optional) |
| ③ Control unit | ⑦ Sampling chamber |
| ④ Disposal line | ⑧ Lifting station |

EasyClean Auto Mix (D+SP) grease separators are designed according to EN 1825-1 and are equipped with an automatically controlled pump for mixing and cleaning of the separators contents and inner walls. These separators are offered with a modern control unit with digital display. It is possible to automate specific steps of the grease separator disposal process. The *EasyClean Auto Mix (D+SP)* separators distinguish themselves through their ease of installation and nearly maintenance free characteristics.

The advantage of the *EasyClean Auto Mix (D+SP)* separators is that disposal can take place through permanently installed disposal lines while the twin covers of the separator remain closed. With this advantage, the disposal truck hooks up to a connection on an exterior wall of the building and, using its own pump, suctions out the entire contents of the separator without any unpleasant odours escaping.

The Shredder-Mix-System macerates and liquifies its contents and also cleans its interior walls all simultaneously. This prepared wastewater is then suctioned into the waiting disposal vehicle. According to DIN V 4040-2, the complete contents of the separator should be emptied, the unit cleaned and refilled with clean cold water every fourteen days or at a minimum of once every month.

Professional advantages

- **Fully automatic direct disposal with program-controlled Shredder-Mix-System for homogenisation of the tank contents**
- **Clean and odour-free disposal and cleaning**
- **Simple control**
- **Low-maintenance operation**
- **Complete System Solution**
In addition to individual grease separators, KESSEL also offers complete separator packages consisting of grease separator, properly matched lifting station and advantageous accessories. All from one source - KESSEL.
- **Individual Solutions**
KESSEL offers a fully staffed Individual Solutions Department with experience in designing and manufacturing drainage products exactly meeting your specifications. For additional information please contact us directly to discuss your requirement. Contact information is found on page 5.
- **Grease separator calculation**

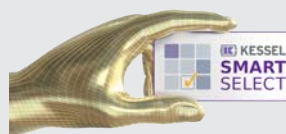

SmartSelect simply makes planning easier – calculation tool for separators at smartselect.kessel.com



Scan this QR code to directly view the corresponding product video.



Installation hints

Important is that a sampling chamber is installed after the outlet of the separator. The separator is installed completely level on a flat firm surface in a frost free area. The height of the room in which the separator is installed should allow easy removal and access of the two lids. In the case that the outlet of the separator is located below the local defined backwater level, a lifting station is to be installed according to EN 12056. In situations where the interruption of separator service is not allowable, a lifting station with double pumps is to be installed.

Notice

EasyClean Auto Mix (D+SP) grease separator is ideal for installations where the presence of strong odours during disposal of the separators contents can not be permitted. The "Shredder-Mix-System" liquifies, macerates and cleans the separators contents all in one step.