

Manhole covers

Manhole covers play an important role in road traffic safety and have to perform their services over many years.

The basic requirements on road traffic safety for manhole covers are specified in EN 124. We at the MeierGuss Group, however, go one stage further. Many of our products meet practice-relevant requirements which are considerably above this standard. The common aim is quality, durability and safety.

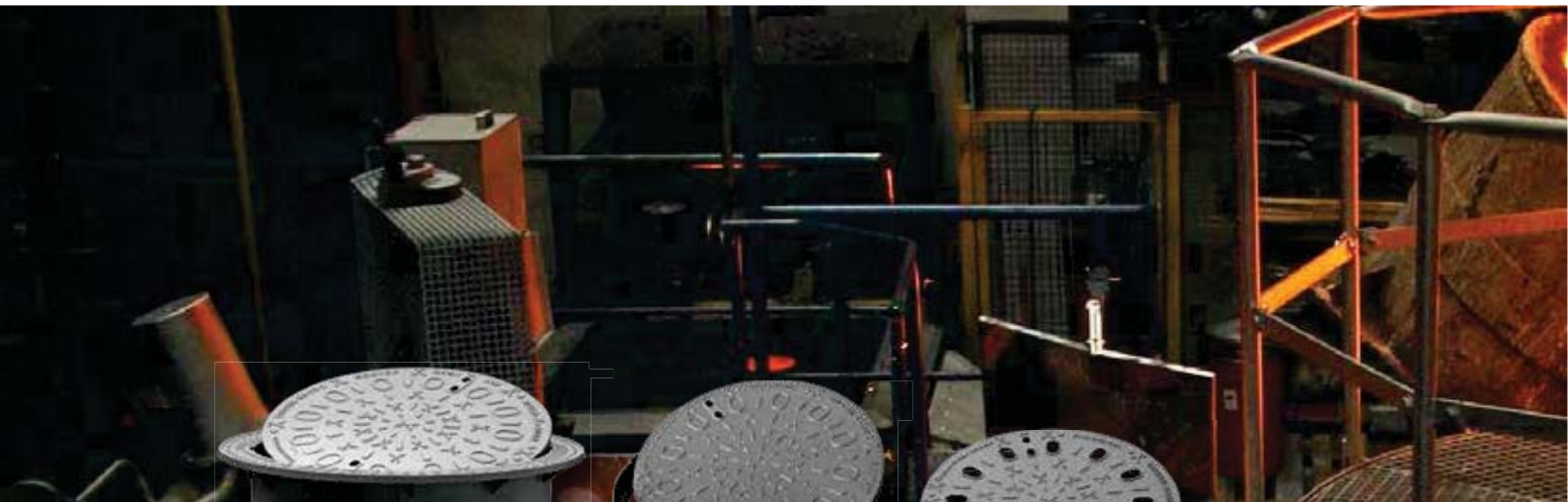

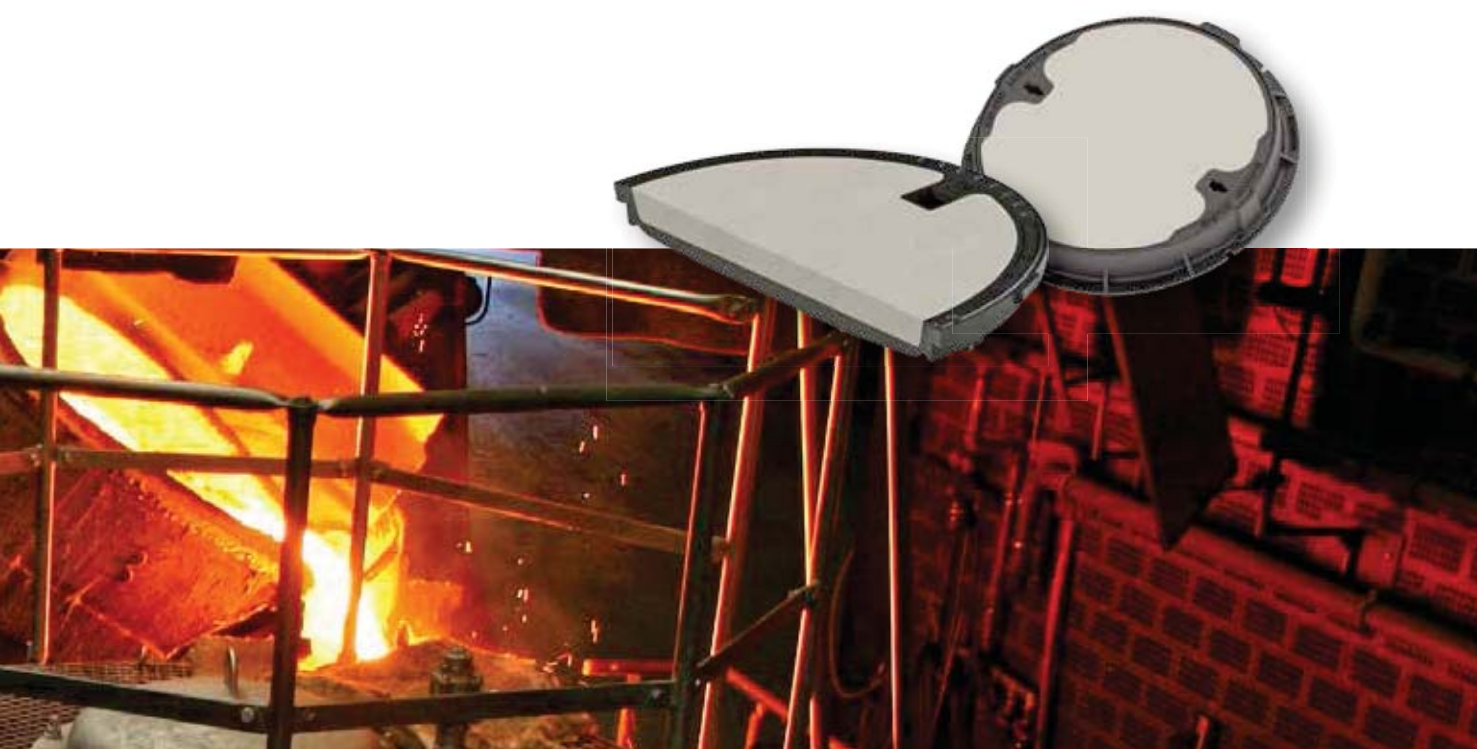

Our range includes both manhole covers with complete cast iron covers and with concrete/cast iron covers.

They provide the optimum mixture of costs, toughness and durability. The two materials of cast iron and concrete bonded to each other permanently and firmly in the right proportions have successfully established themselves in practice over many decades, not just in Germany, but in a wide range of European countries. On top of this, they are also a good solution against theft.

Manhole covers | Class A 15

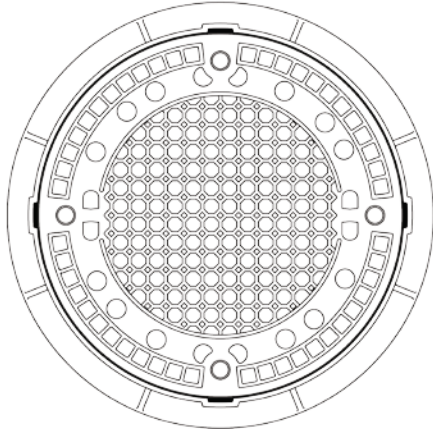
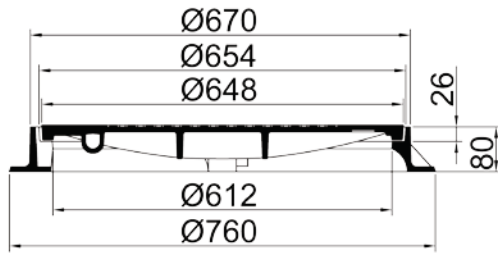

**Manhole cover class A 15,
test force 50 kN,
round, without ventilation,
frame height 80 mm**

Frame: Cast-iron
Cover: Cast-iron

Art.: 801085

20 pcs/pallet | Weight per piece: 58 kg

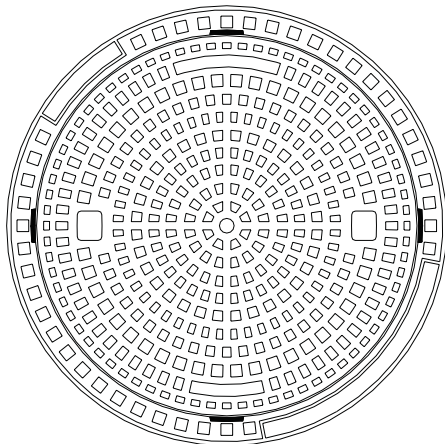
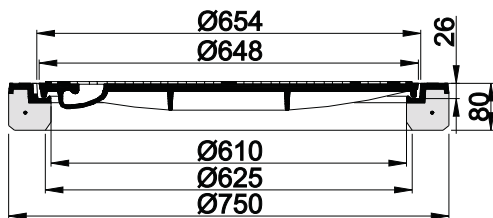

**Manhole cover class A 15,
test force 50 kN,
round, without ventilation, incl. sand-seal
frame height 80 mm**

Frame: Cast-iron and concrete
Cover: Cast-iron

Art.: 101000

12 pcs/pallet | Weight per piece: 70 kg

Here you can see only a brief extract from our manufacturing range. Please contact us if you cannot find the required product.



Exemplary further products | Class A 15



Different covers with coat of arms are possible on request.
Please contact us for further details.

Here you can see only a brief extract from our manufacturing range. Please contact us if you cannot find the required product.

Manhole covers | Class B 125 with / without locking

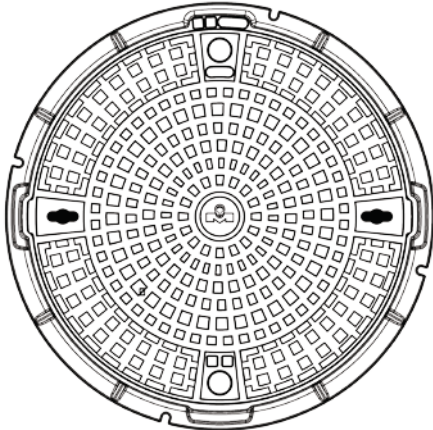
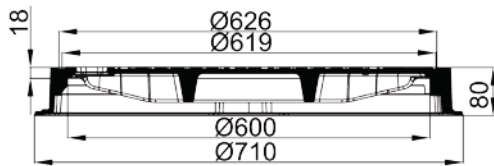

**Manhole cover class B 125,
round, without ventilation,
frame height 80 mm**

Frame: Cast-iron
Cover: Cast-iron

Art.: 802165

20 pcs/pallet | Weight per piece: 53 kg

Further available versions:

20 pcs/pallet | Weight per piece: 53 kg

Art.: 802167

without ventilation, with locking

Art.: 802155

with ventilation

Art.: 802157

with ventilation, with locking

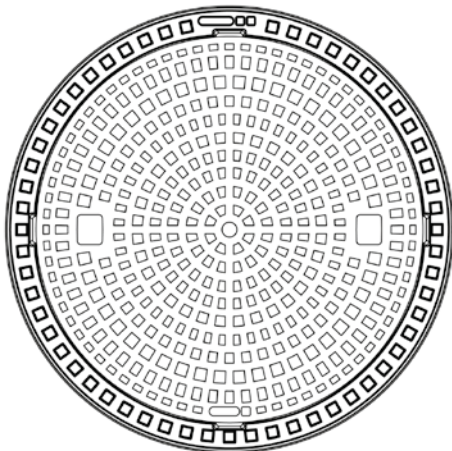
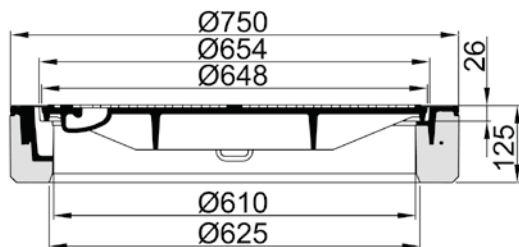

**Manhole cover class B 125,
round, without ventilation,
frame height 125 mm**

Frame: Cast-iron and concrete
Cover: Cast-iron

Art.: 102045

12 pcs/pallet | Weight per piece: 100 kg

Further available version:

12 pcs/pallet | Weight per piece: 100 kg

Art.: 102035

with ventilation

Here you can see only a brief extract from our manufacturing range. Please contact us if you cannot find the required product.



Manhole covers | Class B 125 with / without locking

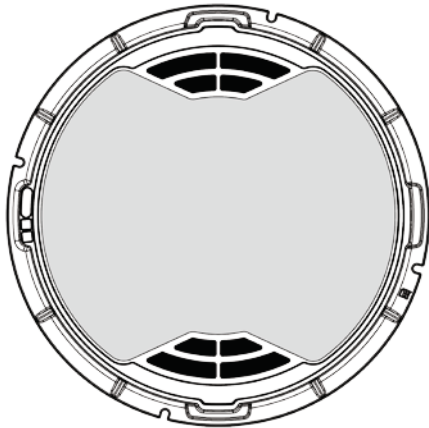
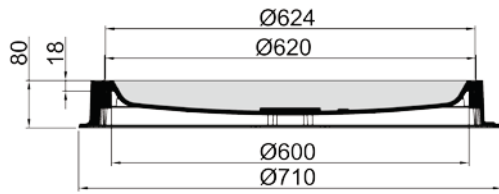

**Manhole cover class B 125,
round, with ventilation,
frame height 80 mm**

Frame: Cast-iron

Cover: Cast-iron and concrete

Art.: 802295

20 pcs/pallet | Weight per piece: 58 kg

Further available versions:

Art.: 802297

with ventilation, with locking

20 pcs/pallet | Weight per piece: 58 kg

Art.: 802280

without ventilation

20 pcs/pallet | Weight per piece: 61 kg

Art.: 802282

without ventilation, with locking

20 pcs/pallet | Weight per piece: 61 kg

Here you can see only a brief extract from our manufacturing range. Please contact us if you cannot find the required product.

Manhole covers | Class B 125

i Locking system for functional products – a guarantee for high-level theft protection

Complete cast iron and concrete/cast iron manhole covers are the first choice in terms of functionality and durability. The subject of theft protection should not be disregarded for such valuable raw materials. Theft does not just result in financial losses, but the accident risk increases enormously.

Example for manhole cover with locking devices (here using article 802167 as an example)



Manhole covers with safety locking devices are secured against unauthorised opening, and lifting due to backpressure, using a catch which swivels into a frame recess and is then firmly tightened. A force-fitting connection is therefore provided. Manhole covers with locking devices are always supplied without damping inserts for safety reasons.

Here you can see only a brief extract from our manufacturing range. Please contact us if you cannot find the required product.



Exemplary further products | Class B 125

Surface water-proof



Covers with coat of arms

Here you can see only a brief extract from our manufacturing range. Please contact us if you cannot find the required product.

Manhole covers | Class C 250 with / without locking

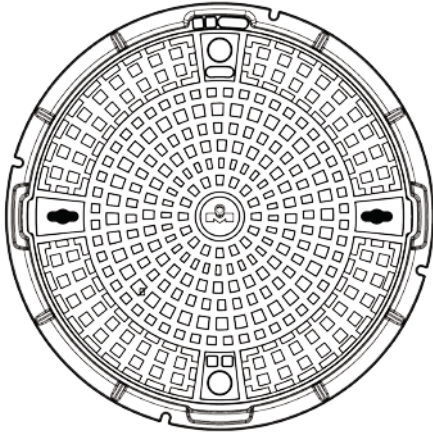
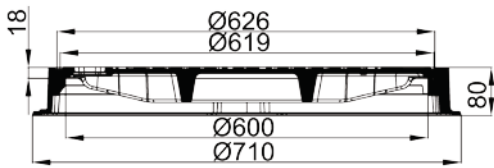

**Manhole cover class C 250,
round, without ventilation,
frame height 80 mm**

Frame: Cast-iron
Cover: Cast-iron

Art.: 803165

20 pcs/pallet | Weight per piece: 59 kg

Further available versions:

20 pcs/pallet | Weight per piece: 58 kg

Art.: 803167
without ventilation, with locking

Art.: 803155
with ventilation

Art.: 803157
with ventilation, with locking

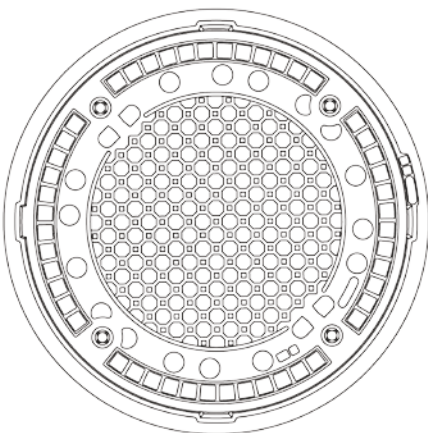
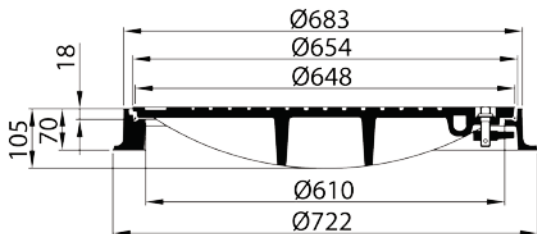

**Manhole cover class C 250,
round, surface water-proof,
with 4 lockings and oil- and petrol
resistant sealing,
frame height 70 mm**

Frame: Cast-iron
Cover: Cast-iron

Art.: 903160

14 pcs/pallet | Weight per piece: 71 kg

Here you can see only a brief extract from our manufacturing range. Please contact us if you cannot find the required product.



Manhole covers | Class C 250 with / without locking

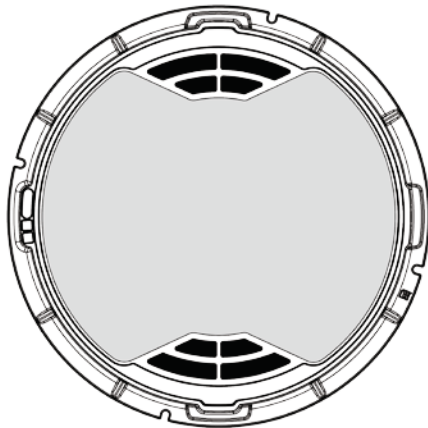
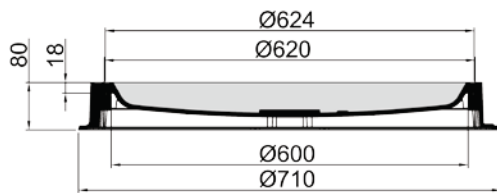

Manhole cover class C 250, round, with ventilation, frame height 80 mm

Frame: Cast-iron
Cover: Cast-iron and concrete

Art.: 803295

20 pcs/pallet | Weight per piece: 61 kg

Further available versions:

Art.: 803297

with ventilation, with locking
20 pcs/pallet | Weight per piece: 61 kg

Art.: 803280

without ventilation
20 pcs/pallet | Weight per piece: 63 kg

Art.: 803282

without ventilation, with locking
20 pcs/pallet | Weight per piece: 63 kg

Here you can see only a brief extract from our manufacturing range. Please contact us if you cannot find the required product.

Manhole covers | Class D 400

with / without locking

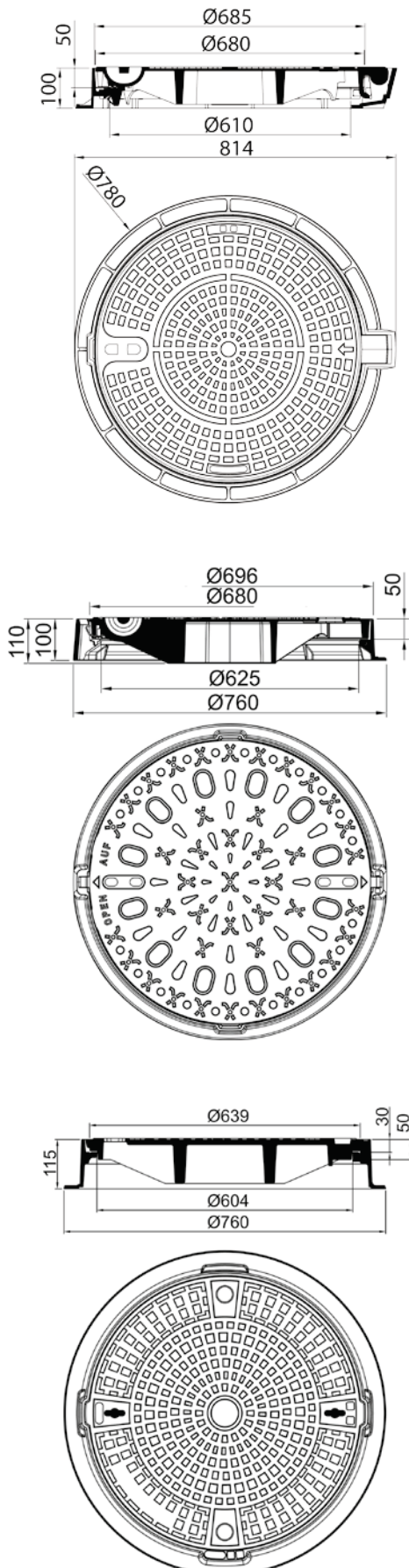

Manhole cover class D 400

System MEITOP®-F with safety hinge
and 2 spring locks

round, without ventilation, frame height 100 mm

Frame: Cast-iron

Cover: Cast-iron

Art.: 104380

Damping insert in frame, Frame with flange, cover can be changed against commercially available DIN covers

10 pcs/pallet | Weight per piece: 75 kg

Further available version:

Art.: 104370, with ventilation

10 pcs/pallet | Weight per piece: 75 kg

Manhole cover class D 400

System ECOTOP® with screw less locking
round, without ventilation, frame height 100 mm
with damping insert MEIPREN®

Frame: Cast-iron

Cover: Cast-iron

Art.: 104880

14 pcs/pallet | Weight per piece: 64 kg

Further available version:

Art.: 104870, with ventilation

14 pcs/pallet | Weight per piece: 78 kg

Manhole cover class D 400, System ECOROAD®

round, without ventilation, frame height 115 mm

Frame: Cast-iron

Cover: Cast-iron

Art.: 804165

10 pcs/pallet | Weight per piece: 92 kg

Further available versions:

10 pcs/pallet | Weight per piece: 92 kg

Art.: 804167

without ventilation, with locking

Art.: 804155

with ventilation

Art.: 804157

with ventilation, with locking



Manhole covers | Class D 400 with / without locking

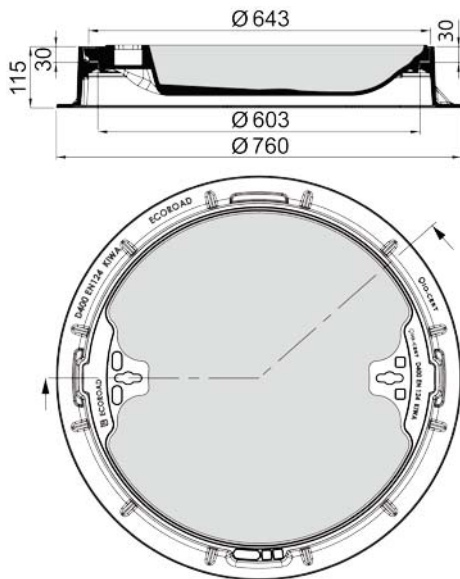

**Manhole cover class D 400
System ECOROAD®
round, without ventilation,
frame height 115 mm**

Frame: Cast-iron
Cover: Cast-iron

Art.: 804280
10 pcs/pallet | Weight per piece: 96 kg

Further available versions:

Art.: 804282
without ventilation, with locking
10 pcs/pallet | Weight per piece: 97 kg

Art.: 804295
with ventilation
10 pcs/pallet | Weight per piece: 93 kg

Art.: 804297
with ventilation, with locking
10 pcs/pallet | Weight per piece: 95 kg

On request also available with 150 mm frame.

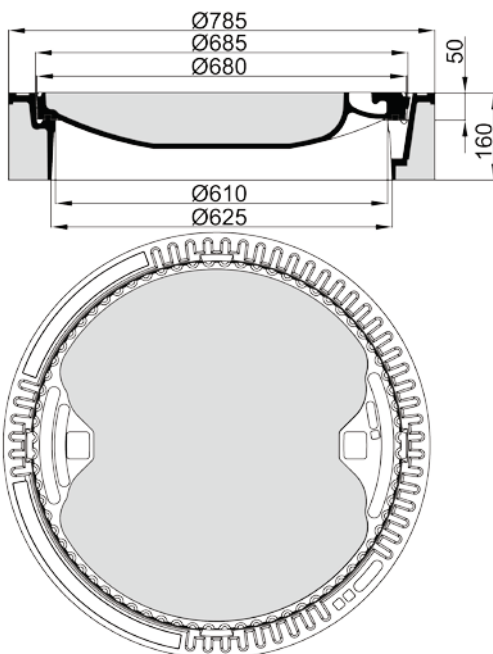

**Manhole cover class D 400
round, without ventilation,
frame height 160 mm
with damping insert MEIPREN®**

Frame: Cast-iron and concrete
Cover: Cast-iron and concrete with damping
insert MEIPREN®

Art.: 894041SF
8 pcs/pallet | Weight per piece: 155 kg

Here you can see only a brief extract from our manufacturing range. Please contact us if you cannot find the required product.

Manhole covers | Class D 400



Locking system for functional products – a guarantee for high-level theft protection

Complete cast iron and concrete/cast iron manhole covers are the first choice in terms of functionality and durability. The subject of theft protection should not be disregarded for such valuable raw materials. Theft does not just result in financial losses, but the accident risk increases enormously.

Example for manhole cover with locking devices (here using article 802167 as an example)



Manhole covers with safety locking devices are secured against unauthorised opening, and lifting due to backpressure, using a catch which swivels into a frame recess and is then firmly tightened. A force-fitting connection is therefore provided. Manhole covers with locking devices are always supplied without damping inserts for safety reasons.

Here you can see only a brief extract from our manufacturing range. Please contact us if you cannot find the required product.



Further manhole covers | Class D 400

Square frame | Individual surface

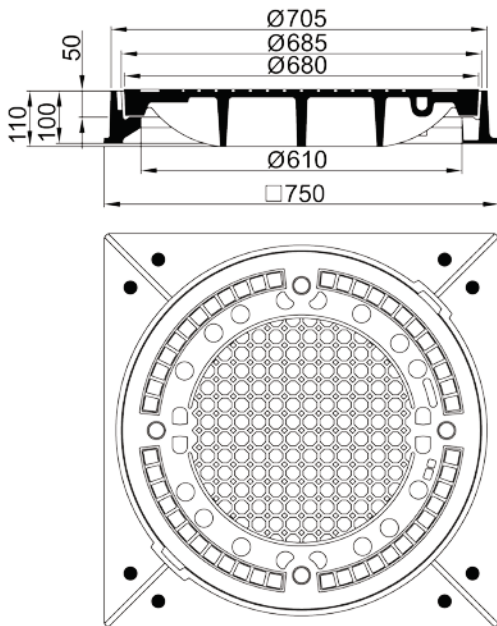

**Manhole cover class D 400
square, without ventilation,
frame height 100 mm**

Frame: Cast-iron
Cover: Cast-iron

Art.: 904125

10 pcs/pallet | Weight per piece: 128 kg

Further available version:

Art.: 904115
with ventilation

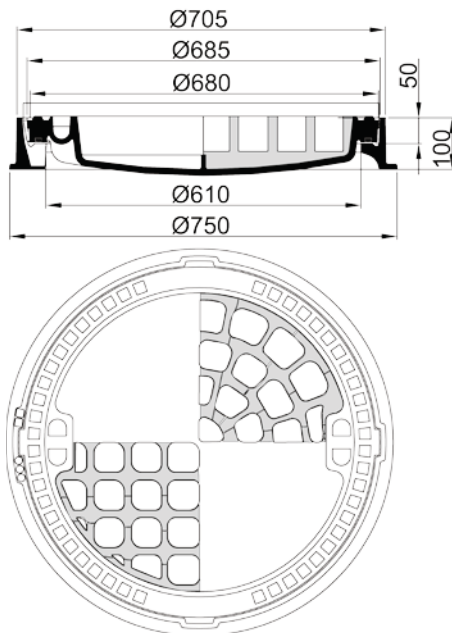

**Manhole cover class D 400
for individual surface,
round, without ventilation,
frame height: 100 mm,
with damping insert MEIPREN®**

Frame: Cast-iron
Cover: Cast-iron for individual surface

Art.: 104180

10 pcs/pallet | Weight per piece: 91 kg

Here you can see only a brief extract from our manufacturing range. Please contact us if you cannot find the required product.

Further manhole covers | Class D 400

surface water-proof

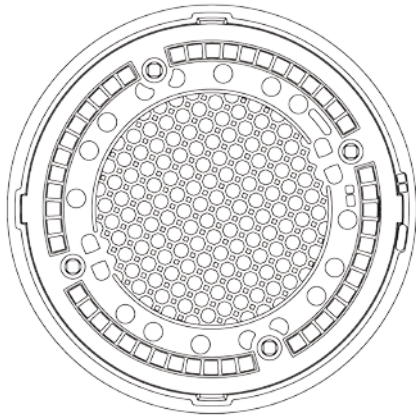
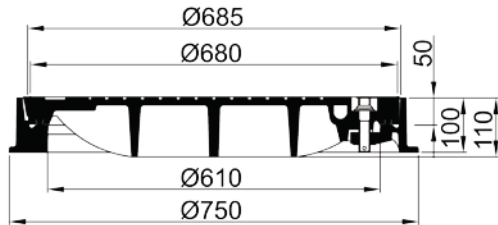

Manhole cover class D 400
round, surface water-proof,
with 4 lockings and oil- and petrol
resistant sealing,
frame height 100 mm

Frame: Cast-iron
Cover: Cast-iron

Art.: 904160

10 pcs/pallet | Weight per piece: 121 kg

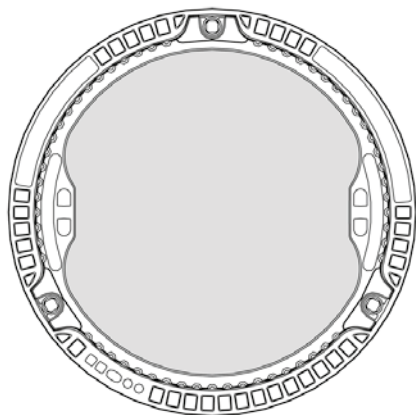
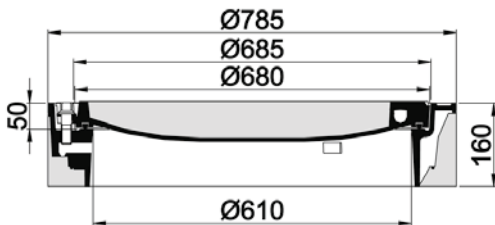

Manhole cover class D 400
round, surface water-proof up to 0.5 bar,
with 3 screw connections and oil-
and petrol resistant sealing,
frame height 100 mm

Frame: Cast-iron and concrete
Cover: Cast-iron and concrete

Art.: 104170

8 pcs/pallet | Weight per piece: 171 kg

Here you can see only a brief extract from our manufacturing range. Please contact us if you cannot find the required product.



Further manhole covers | Class D 400

self-levelling



Self-levelling – always well-bedded

Different movement behaviour of manhole shafts, carriageways and manhole covers can only be compensated with difficulty if the cover frame is placed directly on the shaft. If in this case the carriageway sinks, the cover remains rigidly on the shaft and therefore protrudes above the surrounding area. Manhole covers with rollable frames made in cast iron can adapt themselves to carriageway settlement movement since they are located "floating" in the bitumen carriageway layers.

These outstanding properties are provided by products in the "self-levelling manhole cover" range, products which we are extremely proud of and which have more than established themselves on the market over the last few years.

Benefits at a glance:

- Reducing load on the shaft up to 85 % through direct dissipation of traffic loading into the surrounding layers.
- The cover has an completely level location due to absolute flush installation of the manhole cover by rolling or vibrating into the bituminous carriageway surface.
- Use of standardised covers enables replaceability independent of the manufacturer, and standardised design of road surfaces.
- Further-developed products with hinges or locking techniques are setting new standards.
- The covers fulfil the requirements of loading class D 400 in acc. w. EN 124 in addition to the functional dimensions of DIN 19584.
- Longer period of use compared with conventional covers.

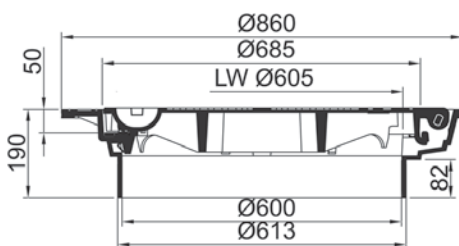

Manhole cover class D 400 self-levelling, System MEITOP®-S, round, without ventilation, with safety hinge and 2 spring locks, incl. damping insert in the frame, for use with adjustment rings conform DIN 4034, frame height 190 mm

Frame: Cast-iron
Cover: Cast-iron

Art.: 104245

5 pcs/pallet
Weight per piece: 103 kg

Further available version:

Art.: 104235
with ventilation

5 pcs/pallet | Weight per piece: 103 kg

Here you can see only a brief extract from our manufacturing range. Please contact us if you cannot find the required product.

Further Manhole covers | Class D 400

self-levelling

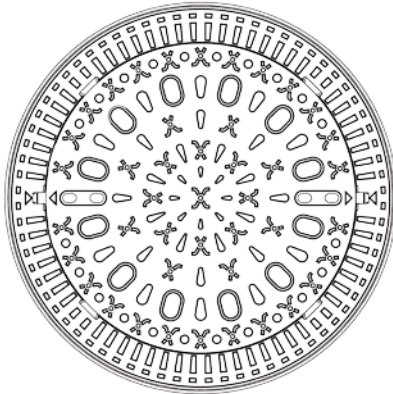
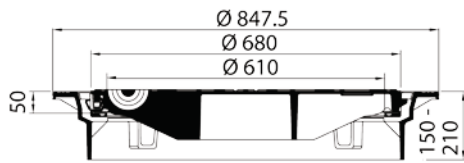

Manhole cover class D 400, self-levelling, System ECOTOP®, round, without ventilation, with screwless locking system and damping insert, frame height 160 mm

Cover: Cast-iron
Frame: Cast-iron

Art.: 104910

5 pcs/pallet | Weight per piece: 85 kg

Further available version:

Art.: 104920
with ventilation

5 pcs/pallet | Weight per piece: 85 kg

Art.: 104295
Concrete guide ring

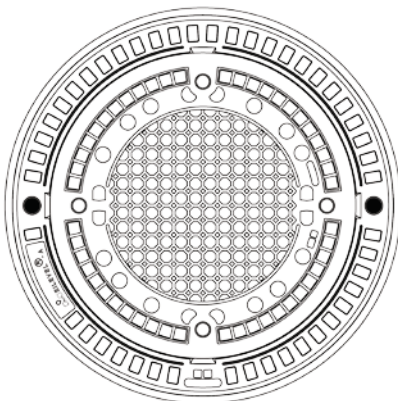
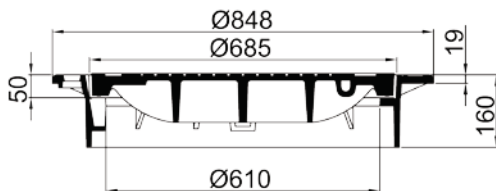

Manhole cover class D 400, self-levelling, System MEILEVEL®-A, round, without ventilation, with rounded frame (especially for use in areas with snowploughs), frame height 160 mm

Cover: Cast-iron
Frame: Cast-iron

Art.: 904266

6 pcs/pallet | Weight per piece: 141 kg

Further available version:

Art.: 904276
with ventilation

6 pcs/pallet | Weight per piece: 141 kg

Art.: 104295
Concrete guide ring

Here you can see only a brief extract from our manufacturing range. Please contact us if you cannot find the required product.



Manhole covers | Class E 600

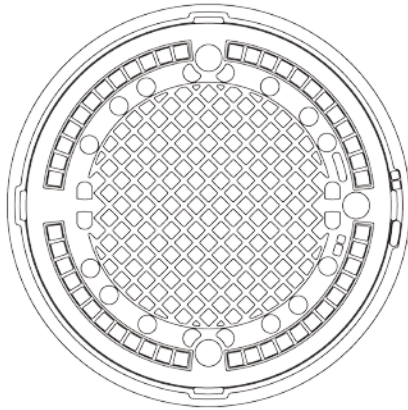
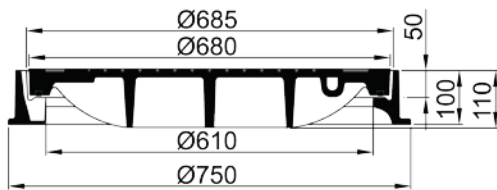

Manhole cover class E 600
round, without ventilation,
frame height 100 mm

Frame: Cast-iron

Cover: Cast-iron

Art.: 905086

10 pcs/pallet | Weight per piece: 120 kg

Further available version:

Art.: 905076

with ventilation

10 pcs/pallet | Weight per piece: 130 kg

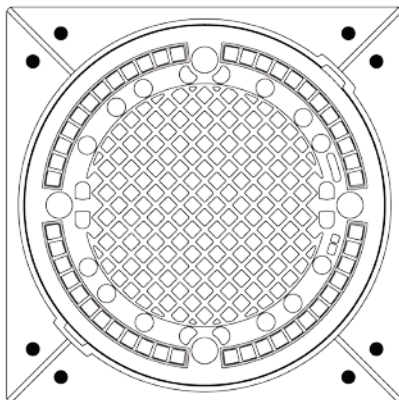
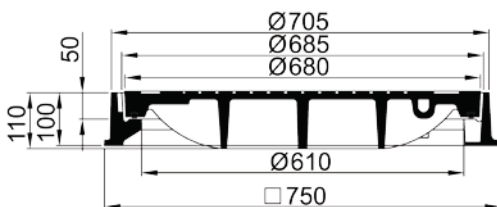

Manhole cover class E 600
square, without ventilation,
with damping insert MEIPREN®
in cover,
frame height 100 mm

Frame: Cast-iron

Cover: Cast-iron

Art.: 905126

10 pcs/pallet | Weight per piece: 120 kg

Further available version:

Art.: 905116

with ventilation

10 pcs/pallet | Weight per piece: 143 kg

Here you can see only a brief extract from our manufacturing range. Please contact us if you cannot find the required product.

Manhole covers | Class F 900

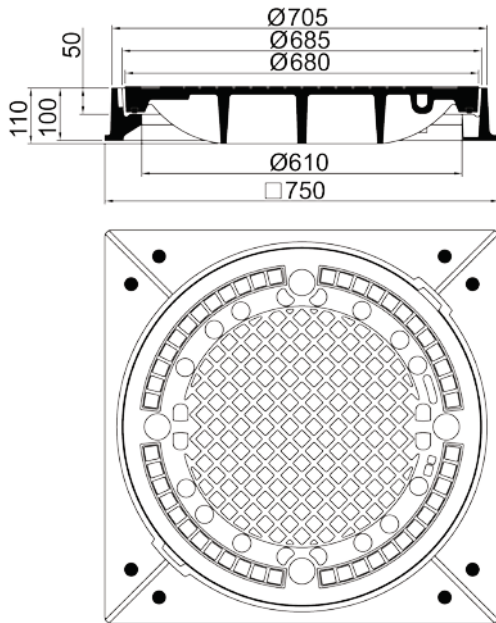

Manhole cover class F 900
square, without ventilation,
frame height 100 mm

Frame: Cast-iron
Cover: Cast-iron

Art.: 906126

10 pcs/pallet | Weight per piece: 137 kg

Further available version:

Art.: 906116
with ventilation

10 pcs/pallet | Weight per piece: 135 kg

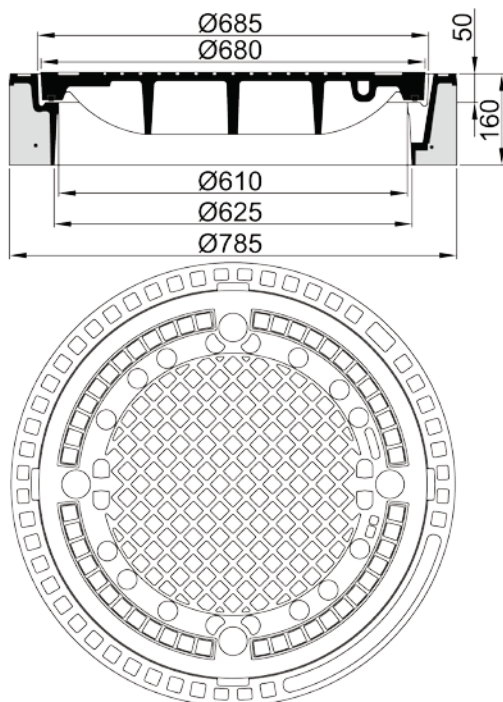

Manhole cover class F900
round, without ventilation,
with damping insert MEIPREN® in cover,
frame height 160 mm

Frame: Cast-iron and concrete
Cover: Cast-iron

Art.: 906046

8 pcs/pallet | Weight per piece: 173 kg

Further available version:

Art.: 906036
with ventilation

8 pcs/pallet | Weight per piece: 172 kg

Here you can see only a brief extract from our manufacturing range. Please contact us if you cannot find the required product.

